

Description

The APC2801 Series is a complete constant-current / constant voltage linear charger for single cell lithium-ion battery. No external sense resistor is needed. No blocking diode is required due to the internal MOSFET architecture. The charger provides various safety features, including battery temperature monitoring to suspend charging when battery temperature is out of safe range. Thermal feedback regulates the charge current to limit the die temperature during high power operation or high ambient temperature. Input current optimizer also regulates the charge current to prevent overloading input power source.

The charge current is programmed by a single resistor, and up to 1A. The charge cycle is terminated when charge current drops to 1/10 of the setting current after the charge-complete voltage is reached, and re-start after battery voltage drops to 150mV below charge-complete voltage.

When the input supply is removed, the device automatically enters a low standby current sleep mode with less than 1µA drawn from battery.

Other features include input over-voltage protection, under voltage lockout, automatic recharge and a status pin.

Applications

- E-cigarette
- Smart Watch
- Wearable Device
- Portable Media Players/Game
- Bluetooth Applications

Package and Order Information

Part number	Charge Full Volatge	Package Description	Temperature Range	Packaging Option	Marking Information
APC2801ADNB	4.2V	DFN-2x2-8L	-40°C ~ 125°C	3000/Tape & Reel	C21A XXXX
APC2801BDNB	4.35V	DFN-2x2-8L	-40°C ~ 125°C	3000/Tape & Reel	C21B XXXX

Features

- **Input operation voltage up to 28V**
- **Input over voltage protection : 6.8V**
- **Programmable charge current up to 1A**
- Charge complete voltage :
 - APC2801ADNB : 4.2V
 - APC2801BDNB : 4.35V
- Trickle charge threshold : 2.7V
- Automatic recharge
- **Reverse connection protection for charging input as well as battery**
- **A low standby current sleep mode without input power supply**
- No current sense resistor required
- Thermal regulation to maximize charge rate without risk of overheating
- **Input voltage limit to maximize input power without overloading adapters problem**
- Battery and ambient temperature monitoring and protection
- RoHS compliant and Lead(Pb)-free DFN2x2-8L package

Pin Configuration and Top Mark

APC2801ADNB

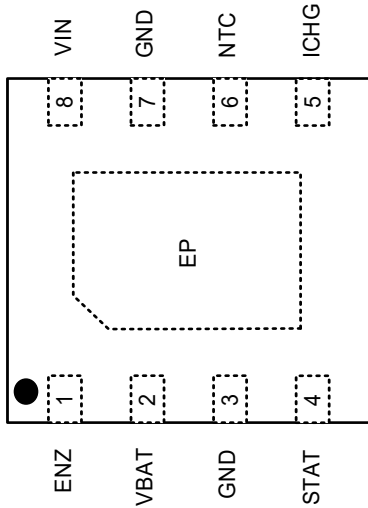

Top View

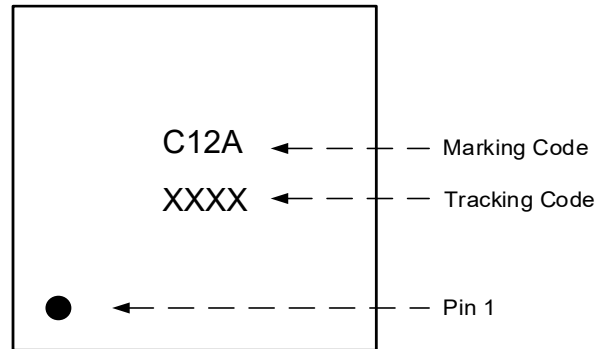

Top Mark

APC2801BDNB

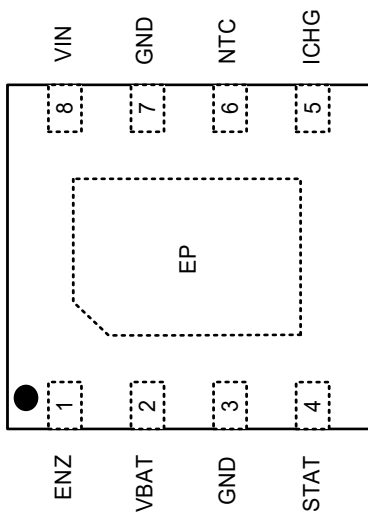

Top View

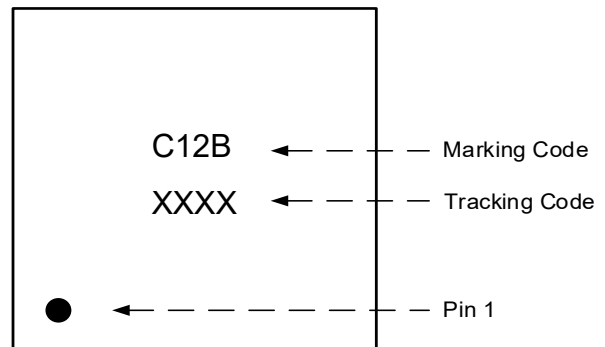

Top Mark

Pin Assignments

Pin	Name	I/O	Description
1	ENZ	Input	Chip enable input. ENZ is active low.
2	VBAT	Power	VBAT is the connection to the battery. Typically a 10 μ F Tantalum capacitor is needed for stability when there is no battery attached. When a battery is attached, at least a 1 μ F ceramic capacitor is required.
3	GND	GND	Ground.
4	STAT	Output	Open-drain output device status. When the battery is charging, STAT is pulled low by an internal MOSFET. When charge is done, STAT is high impedance. During thermal regulation or input voltage regulation, STAT toggles.
5	ICHG	Input	Charge current program. The charge current is programmed by connecting a 1% resistor to ground. DON'T floating.
6	NTC	Input	NTC thermistor input. NTC senses the temperature of the battery pack and stops the charger when the temperature is out of range. Connect to 0.5*VIN to disable this function.
7	GND	GND	Ground.
8	VIN	Power	Input power, connect to external DC supply. Connect minimum 1 μ F ceramic capacitor to ground.
9	EP	GND	This pin must be connected to GND, and punch to the main GND to facilitate heat dissipation.

Function Block Diagram

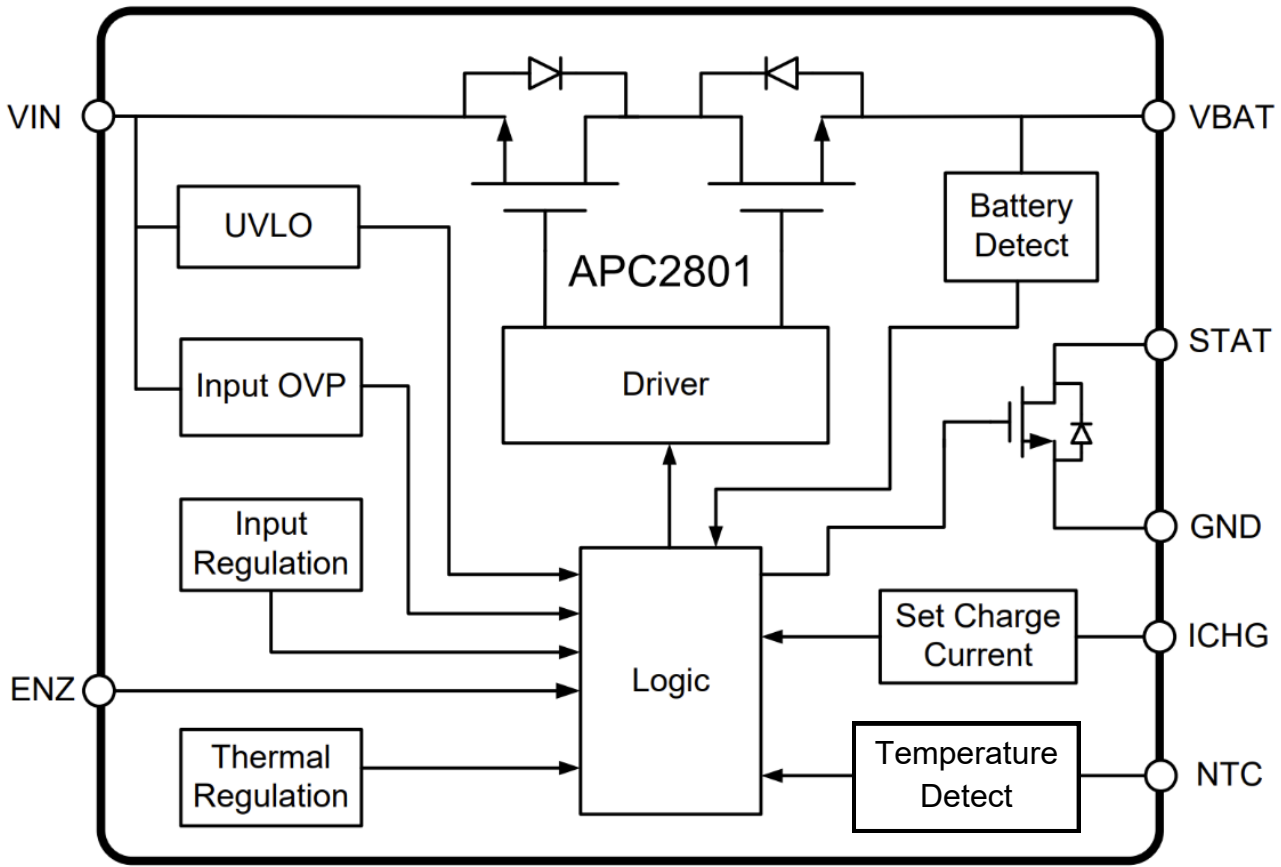

Typical Application Circuit

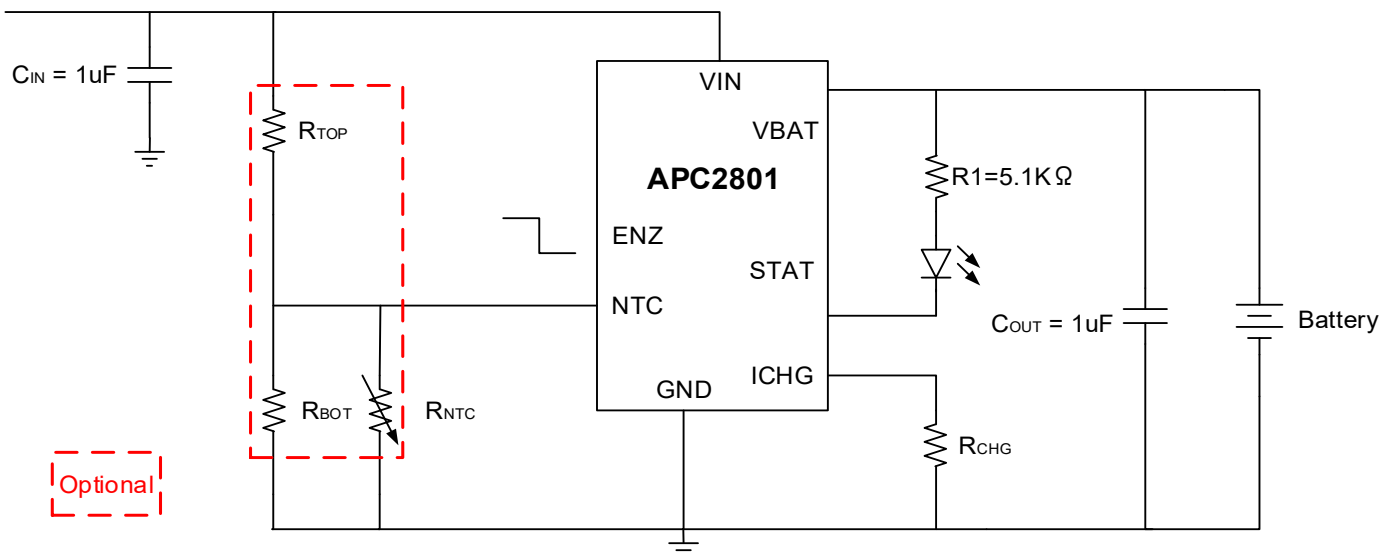

Absolute Maximum Ratings ⁽²⁾ ($T_A = 25^\circ\text{C}$ unless otherwise specified)

Parameter	Symbol	Min	Max	Unit
Input DC voltage	V_{IN}	-0.3	28	V
NTC voltage	V_{NTC}	-0.3	16	V
Battery voltage	V_{BAT}	-0.3	6.5	V
Charge current	I_{CHG}		1	A
ENZ, ICHG, STAT voltage	V_{LV}	-0.3	6.5	V
Ambient temperature	T_A	-40	85	$^\circ\text{C}$
Junction temperature	T_J	-40	125	$^\circ\text{C}$
Storage temperature	T_{STG}	-55	150	$^\circ\text{C}$
Soldering temperature (At leads, 10 seconds)	T_{LEAD}		260	$^\circ\text{C}$

(2) Conditions out of those ranges listed in "absolute maximum ratings" may cause permanent damages to the device. In spite of the limits above, functional operation conditions of the device should be within the ranges listed in "recommended operating conditions". Exposure to absolute-maximum-rated conditions for prolonged periods may affect device reliability.

ESD & Latch-up

Parameter		Symbol	Min	Max	Unit
Human Body Model	APC2801ADNB	V_{HBM}	-3	3	kV
	APC2801BDNB	V_{HBM}	-2	2	kV
Charged Device Model		V_{CDM}	-2	2	kV
Latch-up		$I_{LATCH-UP}$	-200	200	mA

Thermal Information ⁽³⁾

Parameter	Symbol	Value	Unit
Thermal resistance from junction to ambient (In free air)	$R_{\theta JA}$	100	$^\circ\text{C/W}$

(3) Thermal resistance from junction to ambient is highly dependent on PCB layout.

Recommended Operating Conditions

Parameter	Symbol	Min	Max	Unit
Input DC voltage	V_{IN}	3	24	V
NTC voltage	V_{NTC}	0	15	V
ENZ, ICHG, STAT voltage	V_{LV}	0	5	V
Charge current setting resistor	R_{CHG}	14.3	71.5	k Ω
Charge Current Range	I_{CHG}	200	1000	mA
Junction temperature	T_J	-40	125	$^{\circ}\text{C}$

Electrical Characteristics ($V_{IN} = 5\text{V}$, $T_A = 25^{\circ}\text{C}$ unless otherwise specified)

Symbol	Parameter	Conditions	Min	Typ	Max	Units
Input Protection						
V_{IN}	Input Voltage range		3		24	V
V_{UVLO}	Input voltage UVLO on rising			3.3		V
V_{UVLO_HYS}	Input voltage UVLO hysteresis			0.2		V
V_{OVP}	Input overvoltage threshold			6.8		V
V_{OVP_HYS}	Hysteresis of V_{OVP}			0.12		V
t_{OVP}	OVP propagation delay			90		nS
V_{INDPM}	Input voltage limit			4.5		V
I_{OFF}	Shutdown current from input	ENZ floating		8		μA
Logic Input & Output						
V_{IH}	ENZ high input voltage		1.2			V
V_{IL}	ENZ low input voltage				0.4	V
I_{IH}	ENZ internal pull-up current			2		μA
V_{OL}	STAT pull-down voltage	$I_{STAT} = 1\text{mA}$		165		mV
I_{HI_Z}	Leakage current, STAT HI-Z	$V_{STAT} = 5\text{V}$			1	μA

Electrical Characteristics (Continued)

Symbol	Parameter	Conditions	Min	Typ	Max	Units
Battery Charging						
I _{CHG}	Charge current in constant current mode	R _{CHG} = 14.3kΩ		1		A
		R _{CHG} = 28.6kΩ		0.5		A
I _{TRKL}	Trickle charge current	Relative to I _{CHG}		10		%
V _{TRKL}	Trickle charge threshold voltage			2.7		V
V _{TRKL_HYS}	Trickle charge hysteresis voltage			250		mV
I _{TERM}	Termination current threshold	Relative to I _{CHG}		10		%
V _{ICHG}	ICHG pin voltage			0.5		V
V _{FULL}	Charge complete voltage	APC2801ADNB		4.2		V
		APC2801BDNB		4.35		V
V _{RECHG_HYS}	Recharge hysteresis			150		mV
V _{DRP}	V _{IN} to V _{BAT} dropout voltage			150		mV
t _{DGL}	Recharge deglitch time			20		mS
I _{BAT}	V _{BAT} current when not charging	V _{BAT} = V _{FULL}			1	uA
I _{BAT_sleep}	Sleep mode current	V _{BAT} =V _{FULL}		20		nA
Battery Protection						
K _H	Threshold voltage of NTC rising	V _{IN} /V _{NTC} ration		70		%
K _L	Threshold voltage of NTC falling	V _{IN} /V _{NTC} ration		30		%
T _{REG}	Junction temperature in thermal regulation			125		°C

Typical Performance Characteristics (Continued)

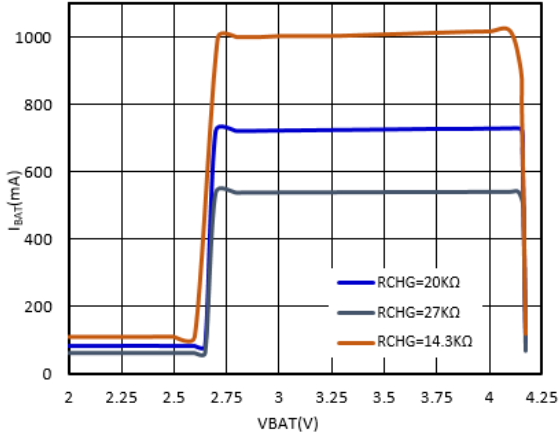

Charge Current vs Battery Voltage

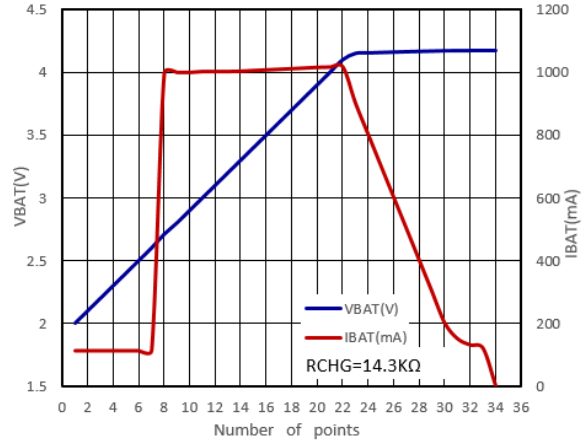

Battery Charge Curve

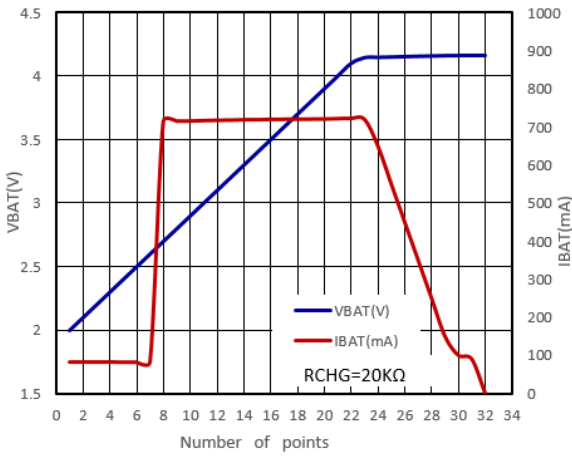

Battery Charge Curve

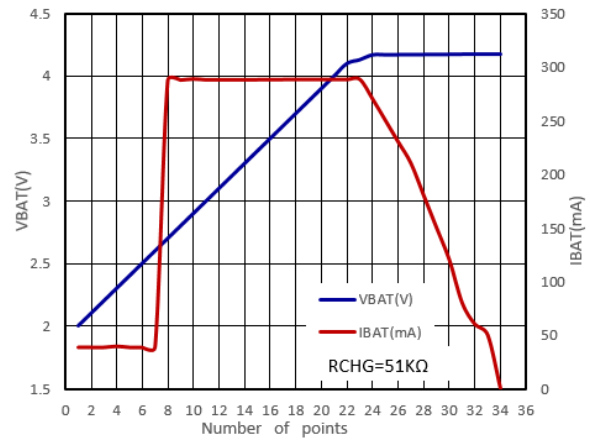

Battery Charge Curve

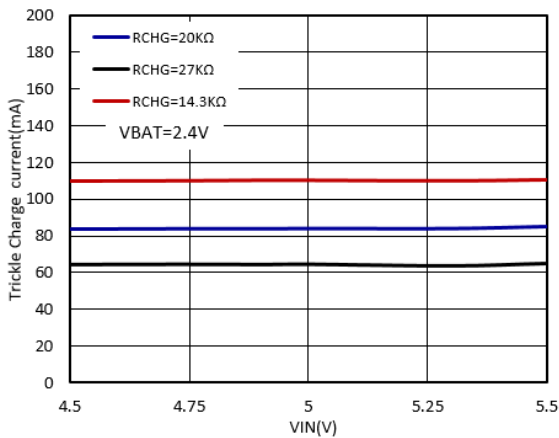

Trickle Charge Current vs Supply Voltage

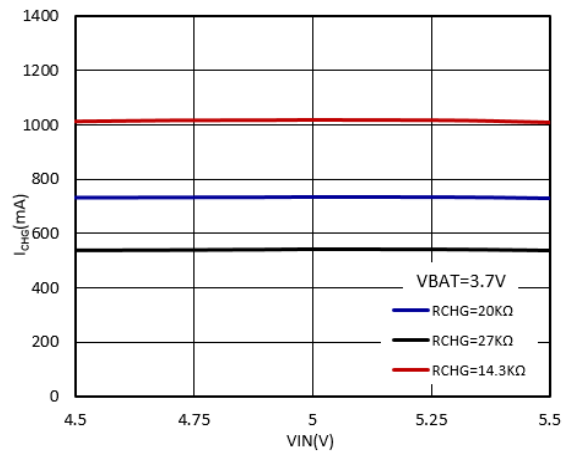

Charge Current vs Supply Voltage

Typical Performance Characteristics ($V_{IN} = 5V$, $C_{IN} = 1\mu F$, $C_{OUT} = 1\mu F$, $R_{TOP} = 9.1k\Omega$, $R_{BOT} = 110k\Omega$, $R_{NTC} = 103AT-2$, $T_A = 25^\circ C$, unless otherwise specified)

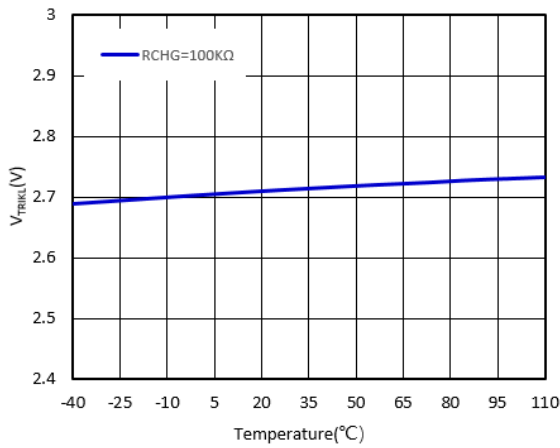

Trickle Charge Threshold vs Ambient Temperature

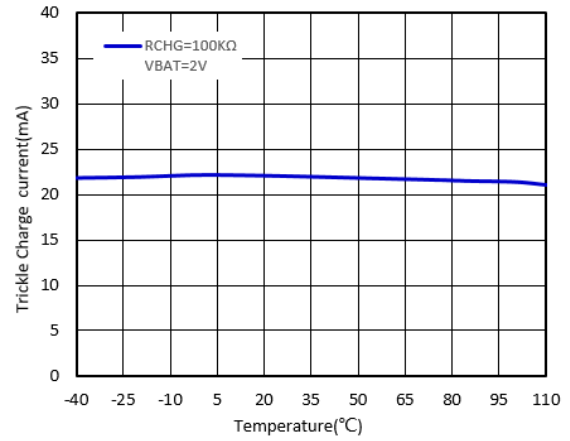

Trickle Charge Current vs Ambient Temperature

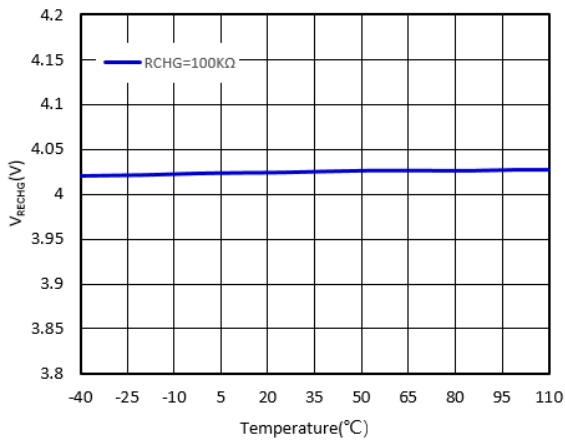

Recharge Voltage Threshold vs Ambient Temperature

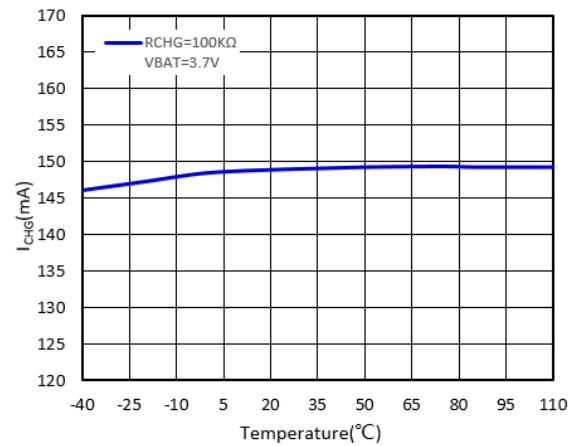

Charge Current vs Ambient Temperature

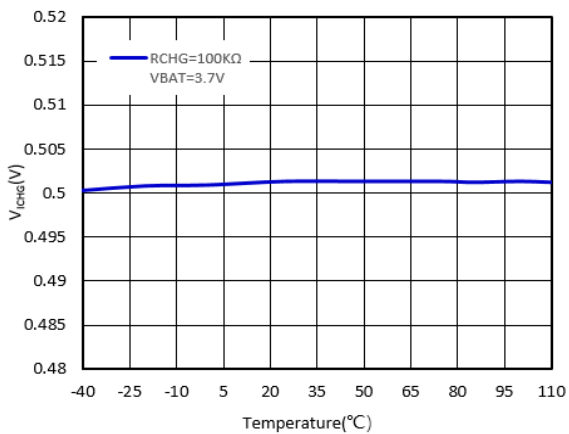

ICHG pin Voltage vs Ambient Temperature

Functional Description

Device Operation

The APC2801 is a single cell Lithium-Ion and Lithium-Polymer battery charger using a constant-current / constant-voltage algorithm. It can deliver up to 1A of charge current with $\pm 1\%$ accuracy for charge-complete voltage. The device includes internal N-channel power MOSFETs. No blocking diode or external current sense resistor is required; thus, the basic charger circuit requires minimum external components.

Normal Charge Cycle

A charge cycle starts when the input voltage rises above the UVLO, but less than OVP, also (VIN - VBAT) is higher than the dropout voltage. A 1% program resistor needs to be connected from the ICHG pin to ground. If the VBAT pin is less than 2.45V, the charger enters trickle charge mode. In this mode, the device supplies approximately 10% of the programmed charge current to bring the battery voltage up to a safe level before full current charging begins.

When the VBAT pin voltage rises above 2.7V, the charger enters constant-current mode, where the programmed charge current is supplied to the battery. When the VBAT pin approaches the charge-complete voltage, the device enters constant-voltage mode and the charge current begins to decrease. The charge cycle ends once the charge current drops below 10% of programmed charge current.

Automatic Recharge

Once the charge cycle is terminated, the device continuously monitors the voltage on VBAT pin. A charge cycle restarts when the battery voltage falls below 150mV below charge-full voltage (which corresponds to approximately 80% to 90% battery capacity). This ensures that the battery is kept at or near a fully charged condition and eliminates the need for periodic charge cycle initiations.

Programming charge current

The charge current is programmed using a single resistor from ICHG pin to ground. The battery charge current of constant current mode is proportional to the current out of ICHG pin. The program resistor and charge current in constant current mode are calculated using the following equations:

$$I_{\text{CHG}} (\text{A}) = 14.3 (\text{A} \cdot \text{k}\Omega) / R_{\text{CHG}} (\text{k}\Omega)$$

For example, when RCHG resistance is set at 14.3K Ω , charge current will be 1A.

Input Voltage Limit (VINDPM)

In case of input power source not capable of providing required charge current, input voltage tends to drop. To avoid overloading input power source, the device has built-in input voltage limit feature to reduce charge current so that input voltage can be maintained no lower than VINDPM threshold, which is fixed at 4.5V.

Thermal Regulation

An internal thermal feedback loop reduces the programmed charge current if the die temperature attempts to rise above a preset value of approximately 125°C. This feature protects the device from excessive temperature and allows the user to push the limits of the power handling capability of a given circuit board without risk of damaging the device. The charge current can be set according to typical (not worst-case) ambient temperature with the assurance that the charger will automatically reduce the current in worst-case conditions.

Functional Description (Continued)

Battery Temperature Protection

The device continuously monitors temperature by measuring the voltage between the NTC and GND pins. A negative temperature coefficient thermistor (NTC) and an external voltage divider typically develop this voltage. The device compares this voltage against its internal K_H and K_L thresholds to determine if charging is allowed. The temperature sensing circuit is immune to any fluctuation in V_{IN} , since both the external voltage divider and the internal thresholds are referenced to V_{IN} .

The resistor values of R_{TOP} and R_{BOT} are calculated by the following equations:

For NTC Thermistors:

$$R_{TOP} = R_{TL} * R_{TH} * (K_H - K_L) / (R_{TL} - R_{TH}) / K_L / K_H$$

$$R_{BOT} = R_{TL} * R_{TH} * (K_H - K_L) / [R_{TL} * (K_L - K_L * K_H) - R_{TH} * (K_H - K_L * K_H)]$$

$K_L = 30\%$, $K_H = 70\%$.

Where R_{TL} is the low temperature resistance and R_{TH} is the high temperature resistance of thermistor, as specified by the thermistor manufacturer. R_{TOP} or R_{BOT} can be omitted if only one temperature (low or high) setting is required. Applying a voltage between the K_L and K_H thresholds to pin NTC disables the temperature-sensing feature.

For example, a battery needs to be charged in the temperature range between 0°C and 60°C , and a NTC of NCP15WF104D is used.

NCP15WF104D	0°C	60°C
Resistance	355.975K Ω	22.224K Ω

Where, $R_{TL}=355.975\text{K}\Omega$, $R_{TH}=22.223\text{K}\Omega$

solve, $R_{top}=45.037\text{K}\Omega$, $T_{bot}=149.634\text{K}\Omega$

Charge Status Indicator

The device has an open-drain status indicator output STAT. STAT is pulled down when the device is in a charge cycle. When charge stops, STAT is high impedance. STAT is toggling between pull-down and high-impedance state in case of thermal regulation, including internal thermal protection and external NTC temperature detection, or VINDPM during charging.

Application Information

Input Overvoltage Protection

If the input voltage rises above V_{OVP} , the charge path is turned off, disconnecting power from the circuit. The response is very fast within 90nS. The STAT pin becomes high impedance. When the input voltage returns between V_{UVLO} and $(V_{OVP} - V_{OVP_HYST})$, the path is turned on again after a deglitch time of t_{DGL} to ensure that the input supply has stabilized.

Shutdown

The device can be shut down by pulling up the EN pin to high voltage more than V_{IH} level. In shutdown mode, the output of the STAT pin is high impedance.

Sleep Mode

Once the input power supply is removed, the device will be put into sleep mode. It has only extreme low current consumption in the BAT Pin.

If input power supply below the UVLO level or $(V_{IN} - V_{BAT})$ is lower than the dropout voltage, the device goes into a low current sleep mode, reducing the battery drain current.

Selection of Input and Output Bypass Capacitors

The input capacitor C_{IN} is for decoupling and serves an important purpose. Whenever a step change downwards in the system load current occurs, the inductance of the input cable causes the input voltage to spike up. C_{IN} prevents the input voltage from overshooting to dangerous levels. It is recommended that a ceramic capacitor of at least 1 μ F be used at the input of the device. It must be located in close proximity to the VIN pin.

C_{OUT} is also important. During an over-voltage transient, this capacitance limits the output overshoot until the pass FET is turned off by the over-voltage protection circuitry. C_{OUT} must be a ceramic capacitor of at least 1 μ F, located close to the VOUT pin. C_{OUT} also serves as the input decoupling capacitor for the charging circuitry downstream.

PCB Layout Guideline

This device is not only a battery charger, but also a protection device, and is meant to protect down-stream circuitry from hazardous voltages. Potentially, high voltages may be applied to this device. It has to be ensured that the edge-to-edge clearance of PCB traces satisfy the design rules for high voltages.

For good thermal performance, the exposed pad should be thermally coupled with the PCB ground plane. Usually this will require a copper pad directly underneath. This copper pad should be connected to the ground plane with an array of thermal vias.

C_{IN} and C_{OUT} should be put close to the device.

Package Outline Drawing

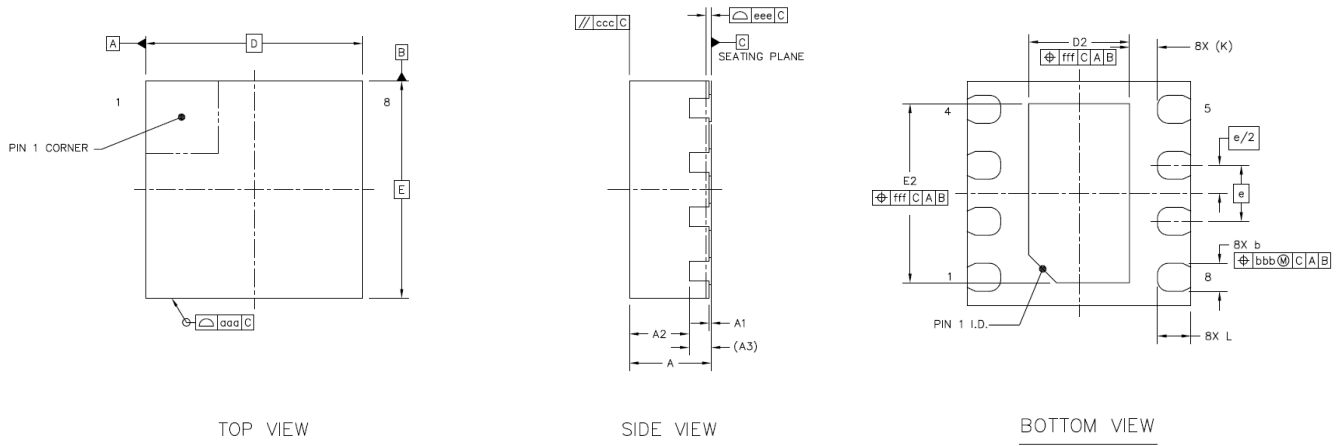

		SYMBOL	MIN	NOM	MAX
TOTAL THICKNESS		A	0.7	0.75	0.8
STAND OFF		A1	0	0.02	0.05
MOLD THICKNESS		A2	---	0.55	---
L/F THICKNESS		A3	0.203 REF		
LEAD WIDTH		b	0.2	0.25	0.3
BODY SIZE	X	D	2 BSC		
	Y	E	2 BSC		
LEAD PITCH		e	0.5 BSC		
LEAD LENGTH		L	0.25	0.3	0.35
EP SIZE	X	D2	0.8	0.9	1
	Y	E2	1.5	1.6	1.7
LEAD TO EP		K	0.15	0.25	0.35
PACKAGE EDGE TOLERANCE		aaa	0.1		
MOLD FLATNESS		ccc	0.1		
COPLANARITY		eee	0.05		
LEAD OFFSET		bbb	0.1		

Contact Information

Applied Power Microelectronics Inc.

Website: <http://www.appliedpowermicro.com>

Email: sales@appliedpowermicro.com

Applied Power Microelectronics Inc. (APM) reserves the right to make changes to the product specification and data in this document without notice. APM makes no warranty, representation or guarantee regarding the suitability of its products for any particular purpose, nor does APM assume any liability arising from the application or use of any products or circuits, and specifically disclaims any and all liability, including without limitation special, consequential or incidental damages.